

\* パーツ ID にアルファベット (ss,a,c 等) が付くパーツは、修理のみ対応いたします。  
 パーツ販売は行っておりませんのであらかじめご了承ください。

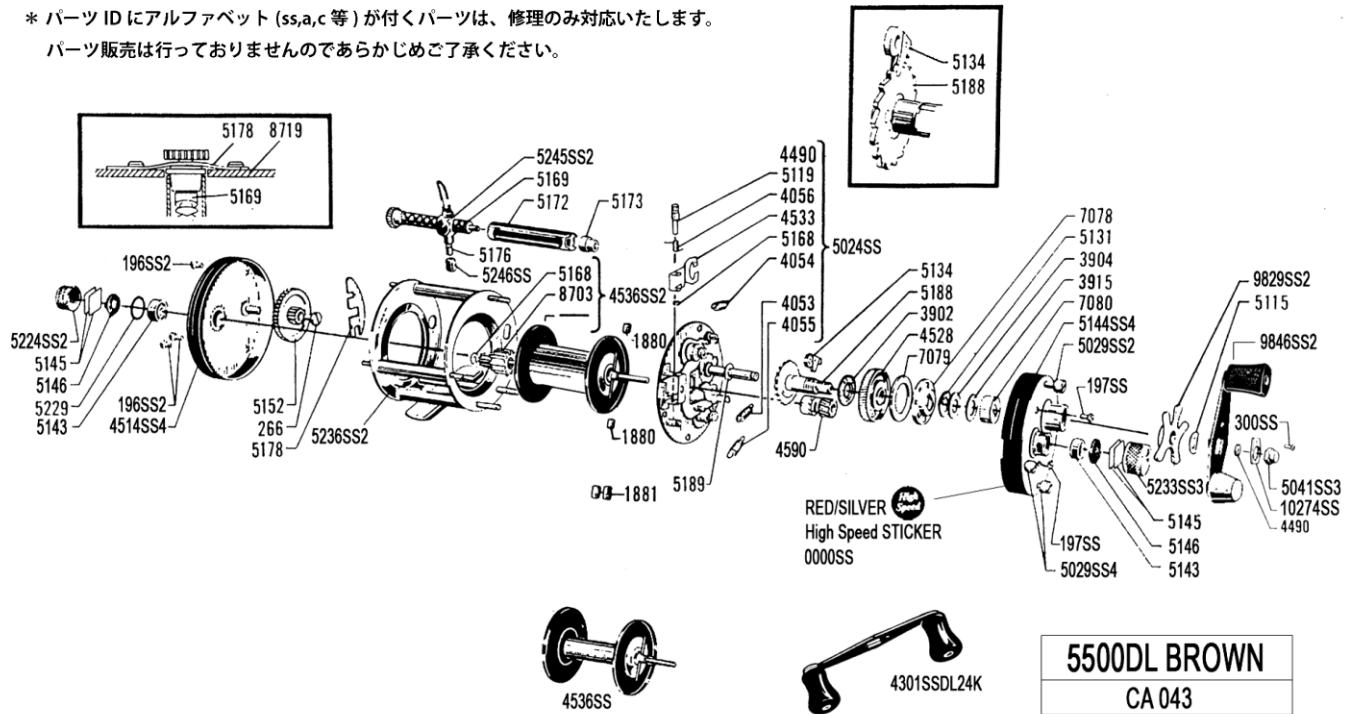

パーツID	パーツ名	価格
266	SCREW M3 X 3.5MM FNGL BRASS	¥200
1880	BRAKE BLOCK MEDIUM (1PIECE)	¥100
1881	BRAKE BLOCK LARGE	¥100
3902	BRAKE WASHER	¥200
3904	WASHER BRASS FNGL	¥200
3915	ADJUSTMENT WASHER	¥200
4053	SPRING S/S 05,2/04	¥200
4054	SPRING	¥200
4055	PRESS ARM SPRG 5500C/6500C	¥200
4056	PINION YOKE SPRG 5500C/6500C	¥200
4490	RETAINER	¥200
4528	MAIN GEAR COMPLETE (SPG.5500C)	¥2,900
4533	CLUTCH CLAW STEEL FNMA	¥1,200
4590	PINION GEAR	¥2,400
5056	BRAKE PLATE COMPLETE ASSY.5000/A/B/D	¥4,800
5115	WASHER	¥200
5119	LOCK PIN 5000	¥300
5131	SPRING WASHER	¥200
5134	ANTI REVERSE PAWL COMPLETE	¥900
5143	SPOOL SHAFT BEARING	¥1,200
5145	BASE WASHER BRONZE(1121573)	¥200
5146	FELT OIL RETAINER 5000	¥200
5152	COG WHEEL	¥600
5168	LOCKING WASHER	¥200
5169	WORMSHAFT COMPLETE(1134360)	¥2,900
5172	LEVEL WIND TUBE BRASS 5000	¥1,900
5173	BEARING	¥200
5176	PILOT GUIDE (51765)	¥600
5178	LOCK PLATE	¥200
5188	MAINGEAR BUSHING COMPLETE	¥2,900
5189	DRIVE SHAFT SHIM 4000-6000	¥200
5229	O-RING	¥200
7078	CLICK WHEEL 5000/6000	¥600
7079	DRAG WASHER	¥600
7080	DRIVE SHAFT BEARING 5-6000	¥500
8703	SPOOL PINION GEAR 5-7000	¥200
8719	FRAME COMPLETE (CHROME)	¥6,600
0000SS		
10274SS	RETINER PLATE 24K	
196SS2		
197SS		
300SS		
4301SSDL		
4514SS4		
4536SS	SPOOL COMPLETE LARGE	
4536SS2		
5024SS	BRAKE PLATE COMPLETE	
5029SS2		
5029SS4		
5041SS3		
5144SS4		

パーツID	パーツ名	価格
5224SS2		
5233SS3		
5236SS2		
5245SS2		
5246SS	LINE CARRIAGE NUT (5500CDL RED)	
9829SS2	STAR WHEEL 24K	
9846SS2		